

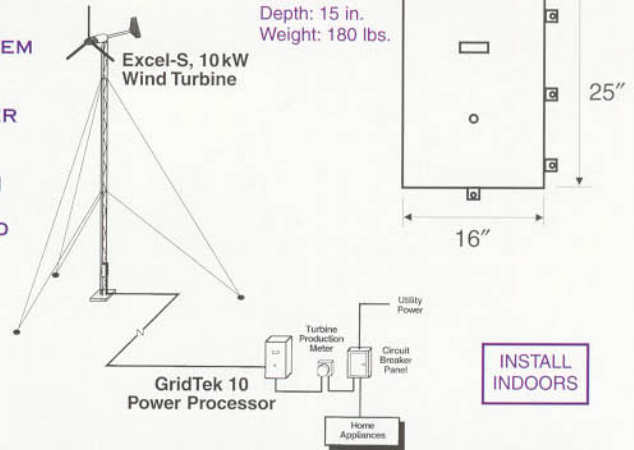

## GRIDTEK 10

- POWER PROCESSOR FOR THE EXCEL-S GRID-INTERIE SYSTEM
- 240 VAC OUTPUT, 60 HZ OR 50 HZ, 220 VAC
- NO BATTERIES, EXCESS POWER IS SOLD TO THE POWER COMPANY
- FULLY AUTOMATIC OPERATION
- ADVANCED DIGITAL DESIGN
- DISPLAYS OUTPUT POWER AND TURBINE SPEED
- 5-YEAR WARRANTY
- UL LISTED
- CEC CERTIFIED



48 V unit, with optional E-Meter



240 V unit

## OPTICHARGE 10

- RECTIFIER AND REGULATOR FOR THE EXCEL-R BATTERY CHARGING SYSTEM
- 24, 48, 120, OR 240 VDC OUTPUTS
- SOLID-STATE, PASSIVE COOLING (EXCEPT 24 V UNIT)
- OPTICHARGE, CONSTANT VOLTAGE CHARGING, FOR LONGER BATTERY LIFE
- FULLY AUTOMATIC OPERATION
- DISPLAYS BATTERY VOLTAGE AND CHARGING STATUS
- OPTIONAL INTEGRATED DC POWER CENTER
- 5-YEAR WARRANTY

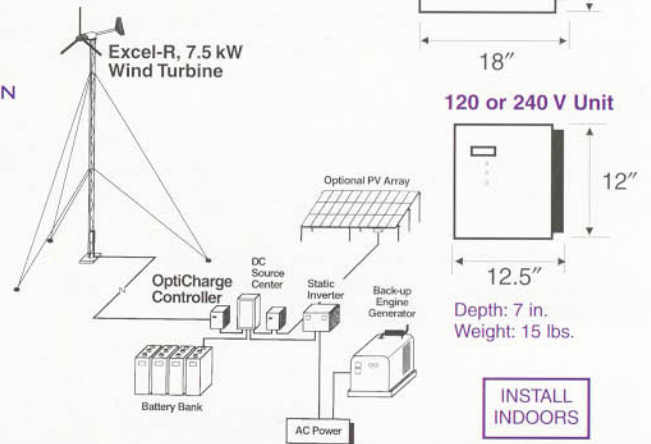

## PUMPTEK 10

- PUMP CONTROLLER FOR THE EXCEL-PD WIND-ELECTRIC PUMPING SYSTEM
- NEW IMPROVED DESIGN
- SOLID-STATE, NO BATTERY
- FOR STANDARD 240 VAC 3-PH PUMPS
- FULLY AUTOMATIC OPERATION
- DRY PUMP SHUTDOWN
- OUTDOOR RATED ENCLOSURE
- 5-YEAR WARRANTY

